

Date:	
Project Name:	
SKU #:	

**ELEMENT™ TROFFER**  
Direct/Indirect Architectural Troffer



**APPLICATIONS**

Commercial, Retail, Institution, and Hospitality

**FEATURES**

- |   |   |
|---|---|
| <p><b>Construction</b></p> <p>Dieformed 6" deep housing, 22-gauge prime cold rolled steel with high reflected powder coating finish. Heavy gauge end plates are securely attached with screws for strength and rigidity and the elimination of gaps.</p> <p><b>Electrical &amp; Technical</b></p> <ul style="list-style-type: none"> <li>- Input Voltage: 120-277VAC</li> <li>- Input Frequency: 50/60Hz</li> <li>- Projected L70 &gt; 50,000 hrs</li> <li>- PF: &gt;0.9</li> <li>- CRI: &gt;80 or &gt;90* [Option]</li> <li>- THD: &lt;20%</li> <li>- CCT: 3500K, 4000K, or 5000K</li> <li>- Operating Temp.: -40°F ~ 104°F</li> <li>- Damp Location Rated</li> <li>- Emergency Battery Backup Driver [Option] [Factory Installed]</li> <li>- 15W Emergency Inverter [Option]</li> <li>- 10W Bodine Inverter [Option]</li> </ul> <p><b>Controls</b></p> <ul style="list-style-type: none"> <li>- 0-10V Dimming (Dims to 10%) [Standard]</li> <li>- 0-10V Dimming (Dims to 1%)</li> </ul> <p><b>Lumen Output</b></p> <ul style="list-style-type: none"> <li>• 2'x2': 20W (2,500lm)</li> <li>• 2'x2': 30W (3,750lm)</li> <li>• 2'x4': 30W (3,750lm)</li> <li>• 2'x4': 40W (5,000lm)</li> </ul> | <p><b>Finish</b></p> <ul style="list-style-type: none"> <li>- White</li> </ul> <p><b>Optical</b></p> <ul style="list-style-type: none"> <li>- Reflector has high reflectance baked matte white enamel finish for luminous uniformity.</li> </ul> <p><b>Installation/Mounting</b></p> <ul style="list-style-type: none"> <li>- Recessed Mount</li> <li>- Flange Mount Kit</li> </ul> <p><b>Compliance</b></p> <ul style="list-style-type: none"> <li>- JA8 TITLE 24 Compliant at 90CRI</li> </ul> <p><b>Warranty</b></p> <ul style="list-style-type: none"> <li>- 5 Year Warranty</li> <li>- See warranty documentation for more information.</li> </ul> |
|---|---|



**ORDERING INFORMATION** **EXAMPLE: ELE-22-20-40**

Series	Size	Wattage	CCT	CRI	Dimming	Emergency Driver
ELE	22 - 2'x2'	20 - 20W 30 - 30W	35 - 3500K 40 - 4000K 50 - 5000K	(Blank) 80CRI (Standard) 90CRI* - True Color Render	(Blank) 0-10V D1* - 0-10V (1%)	(Blank) No EM EM - 8W Emergency Driver
	24 - 2'x4'	30 - 30W 40 - 40W				

Flange Mount Kit	Accessories
8822-FMK (2x2 Flange Mount Kit) 8824-FMK (2x4 Flange Mount Kit)	88-WP8-3C (8': 3 Wire Whip [18AWG]) ELIS10CDF (10W Bodine Inverter) TGS-15W-INT (15W Emergency Inverter)

**DIMENSIONS**

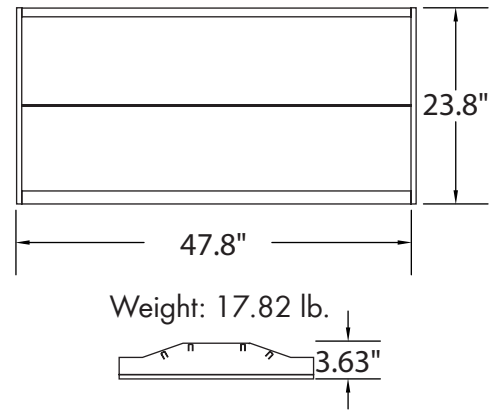
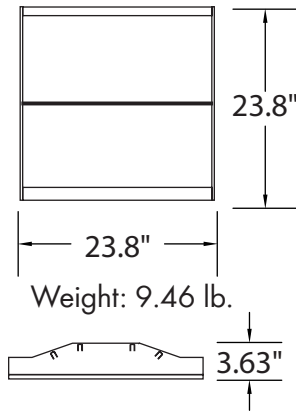

**LUMEN OUTPUT**

SKU	Size (LxW)	Wattage (W)	Delivered Lumens (lm)	Efficacy (lm/W)
ELE-22-20-50	2'x2'	20	2500	125
ELE-22-30-50	2'x2'	30	3750	125
ELE-24-30-50	2'x4'	30	3750	125
ELE-24-40-50	2'x4'	40	5000	125

**ACCESSORIES**



8' Three Wire Whip  
(Option)  
[88-WP8-3C]



Bodine Inverter  
10W  
(Option)  
[ELIS10CDF]



Emergency  
Inverter 15W  
(Option)  
[TGS-15W-INT]



Flange  
Mount Kit  
2'x2', 2'x4'  
(Option)  
[8822-FMK]  
[8824-FMK]